

Name: _____ **SOLUTION** _____ (please print)

Signature: _____

ECE 2201 – Final Exam
May 2, 2019

**Keep this exam closed until you
are told to begin.**

1. This exam is closed book, closed notes. You may use one 8.5" x 11" crib sheet, or its equivalent.
2. Show all work on these pages. Show all work necessary to complete the problem. A solution without the appropriate work shown will receive no credit. A solution that is not given in a reasonable order will lose credit. Clearly indicate your answer (for example by enclosing it in a box).
3. It is assumed that your work will begin on the same page as the problem statement. If you choose to begin your work on another page, you must indicate this on the page with the problem statement, with a clear indication of where the work can be found. **If your work continues on to another page, indicate clearly where your work can be found. Failure to indicate this clearly will result in a loss of credit.**
4. Show all units in solutions, intermediate results, and figures. Units in the exam will be included between square brackets.
5. Do not use red ink. Do not use red pencil.
6. You will have 160 minutes to work on this exam.

1. _____/35

2. _____/30

3. _____/35

4. _____/30

5. _____/35

6. _____/35

Total = 200

Room for extra work

1. {35 Points} Use the **node-voltage method** to write a complete set of equations that could be used to solve this circuit. Do not simplify the circuit. Do not attempt to simplify or solve your equations. **Define all variables clearly.**

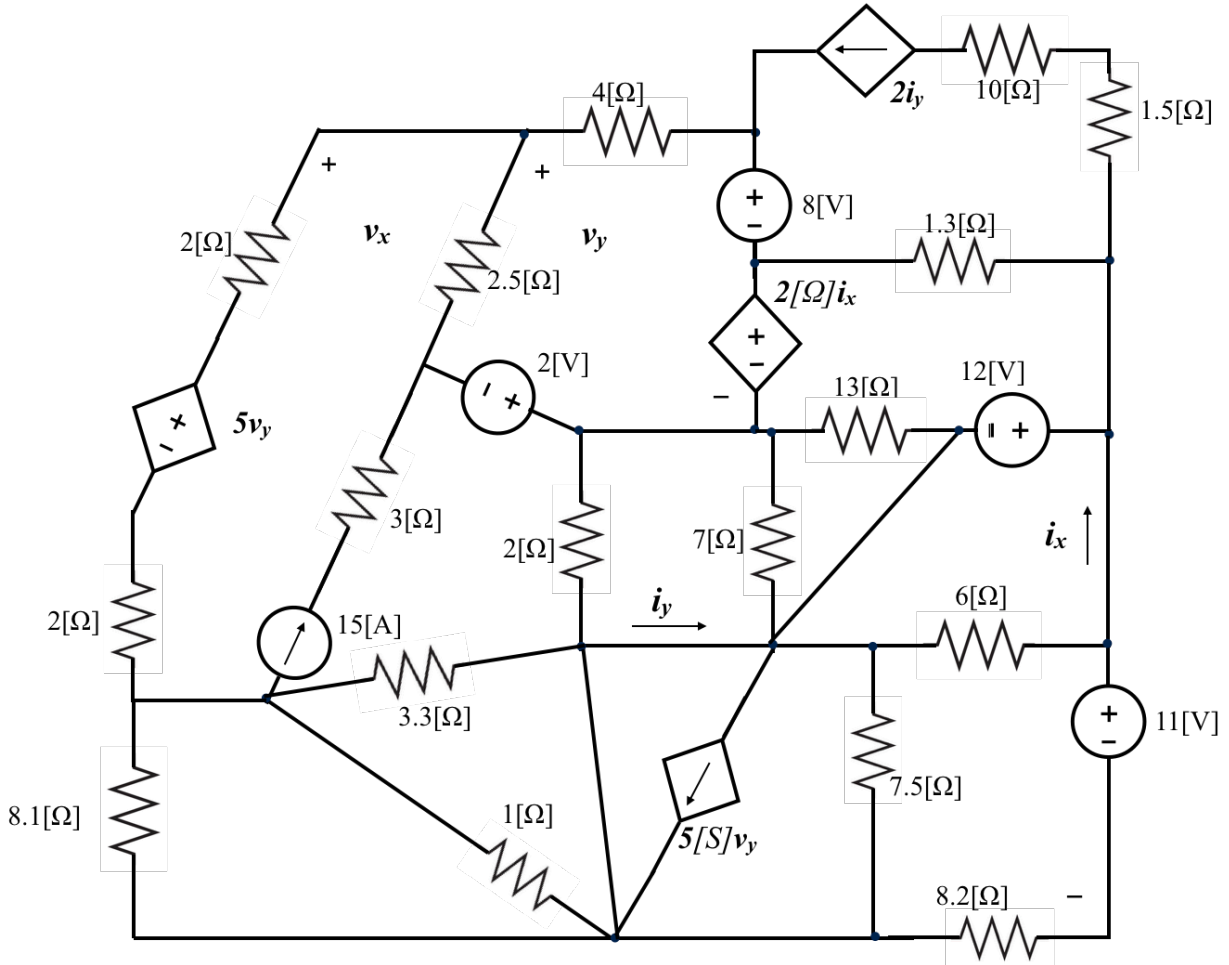

Room for extra work

2. {30 Points} Use the circuit shown below to solve.

- Find and draw the Norton equivalent seen by the independent current source 3[mA].
- Find the power delivered by the independent current source 3[mA].
- Which way (direction) electrons are moving when crossing the terminal A?

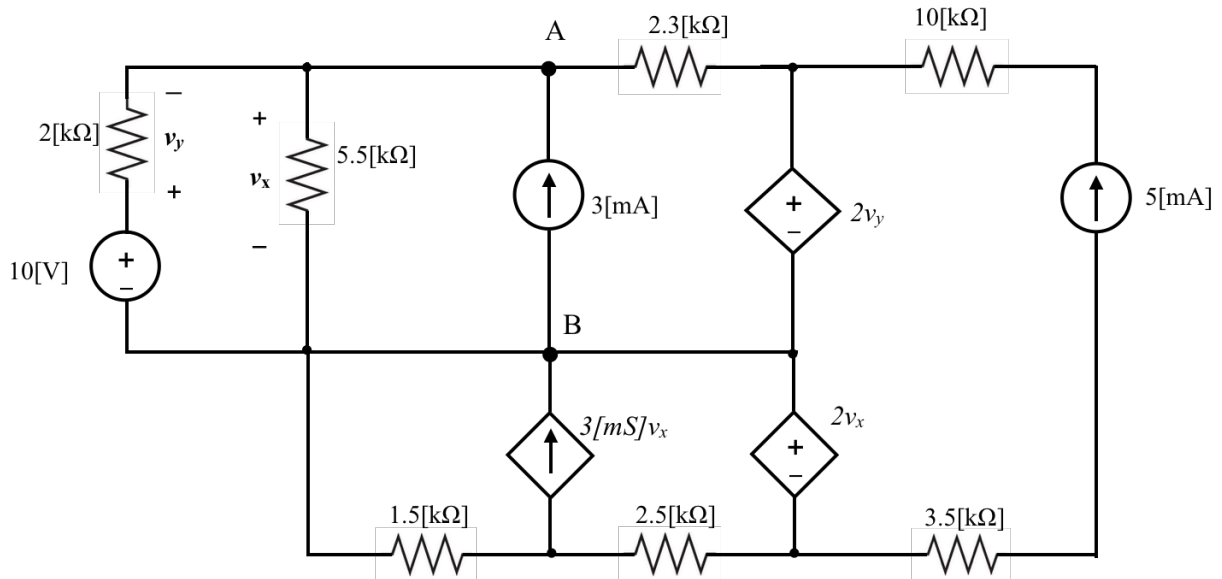

Room for extra work

3. {35 Points} A device shown in Figure 1 can be modeled as a voltage source in series with a resistance. The relationship between the voltage across the device and the current through the device is shown in Figure 1. This device is connected to the circuit as shown in Figure 2.

Power delivered by the independent current source 1[mA] is measured as 7.5 [mW].

a) Find the model of this device operating in the circuit below (Figure 2), and draw it, showing terminals **A** and **B**.

b) Find the coefficient **k** in the dependent voltage source $k v_x$.

c) Are the electrons losing or gaining energy while moving through the dependent voltage source $k v_x$? Briefly explain your answer.

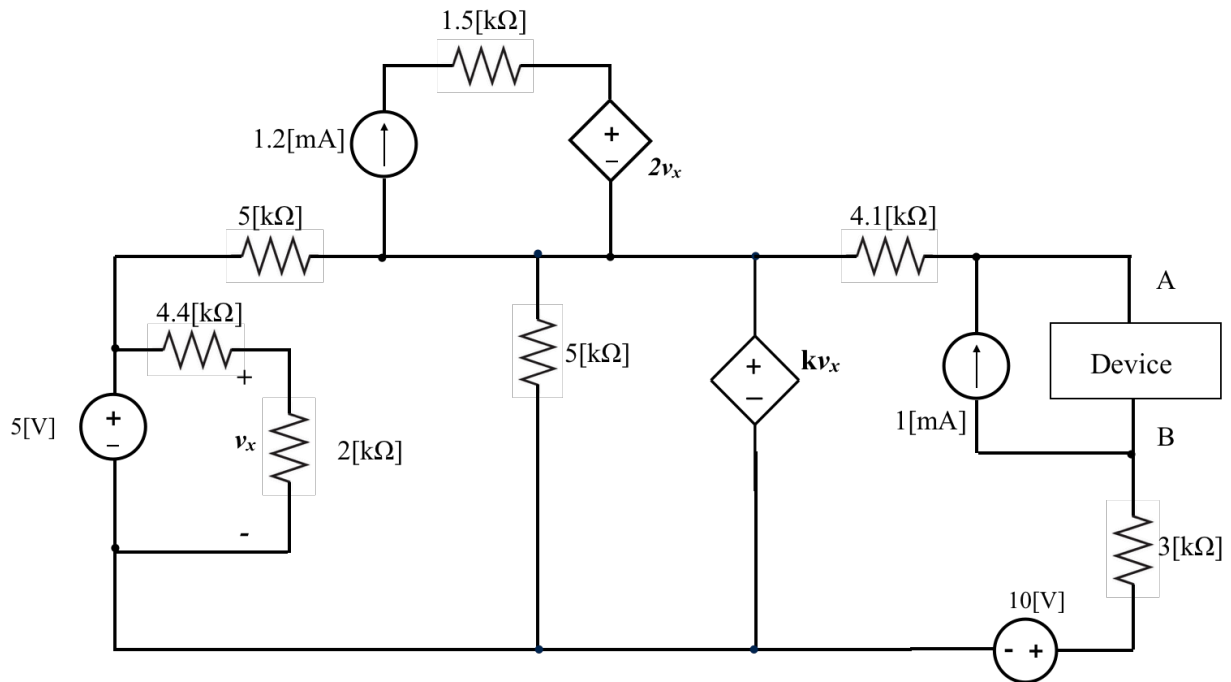
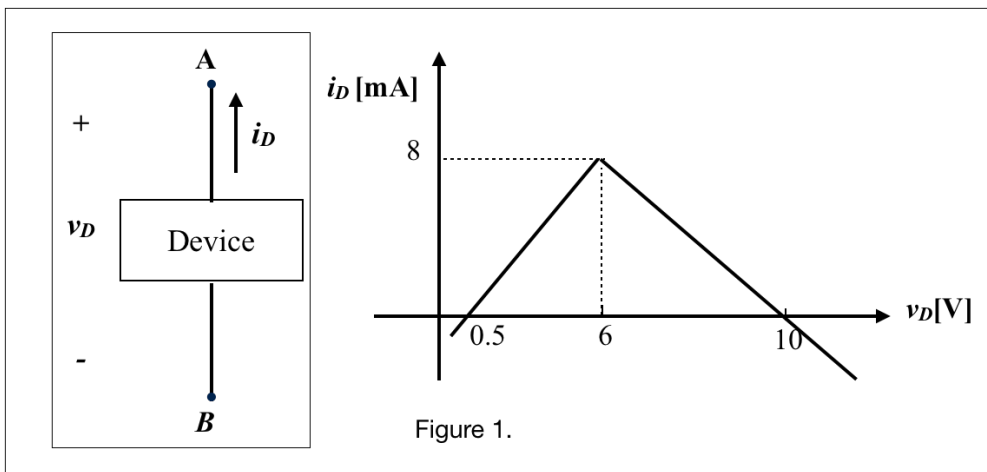

Room for extra work

4. {30 Points} **Do not** use the Node-Voltage Method or Mesh-Current Method to solve this problem.

a) Simplify the following circuit and find v_b .

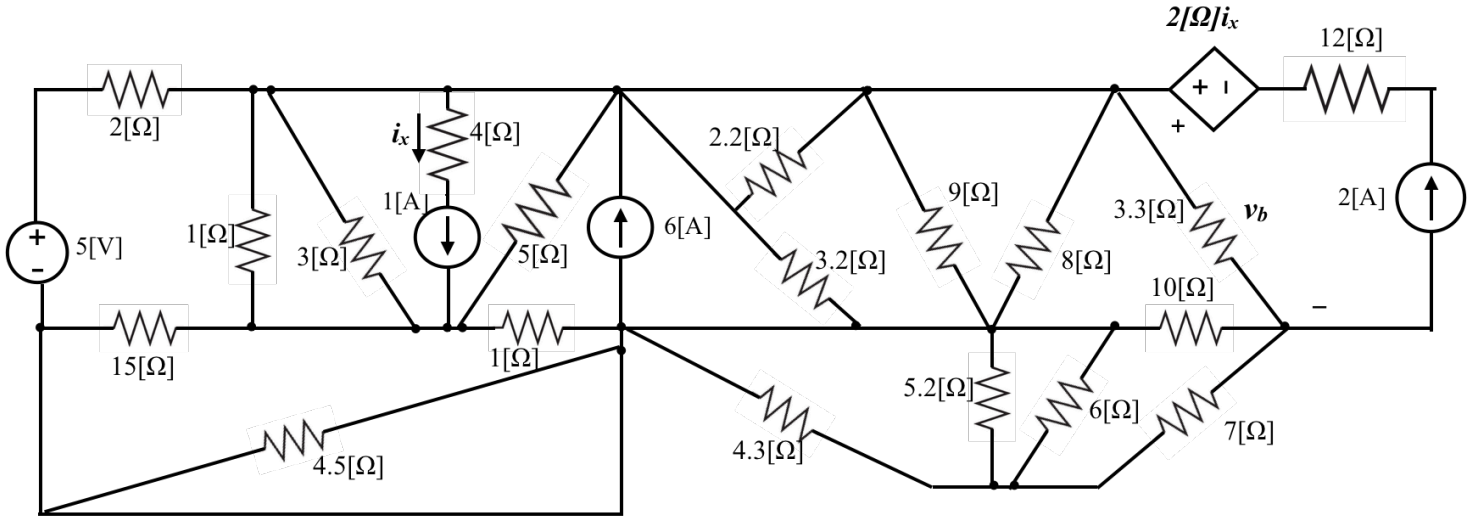

Room for extra work

5. {35 Points} In the following circuit, we will connect a load resistor R_L that will ensure maximum power delivered to this load R_L .

- Find the value of R_L for this maximized power delivery.
- Find the Thevenin equivalent seen by R_L and draw it showing terminals A and B.

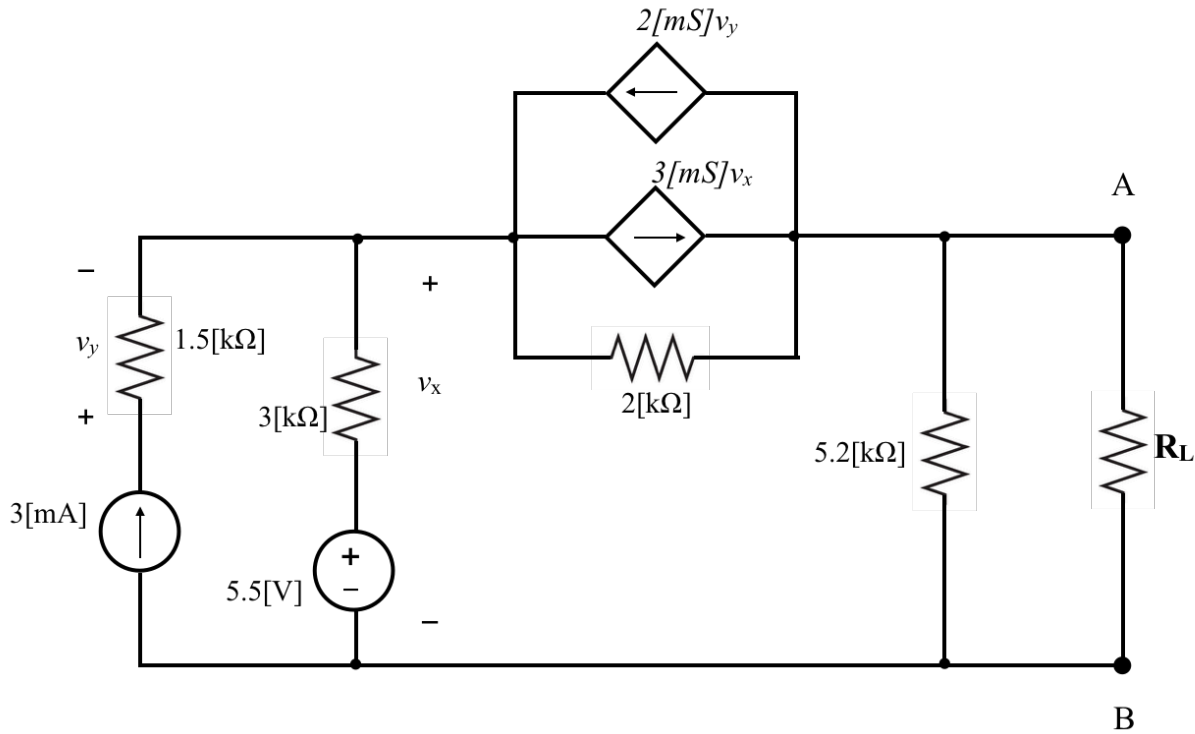

Room for extra work

6. {35 Points} Use the circuit shown below to solve this problem.
 a) Use the superposition principle to find the voltage v_b .

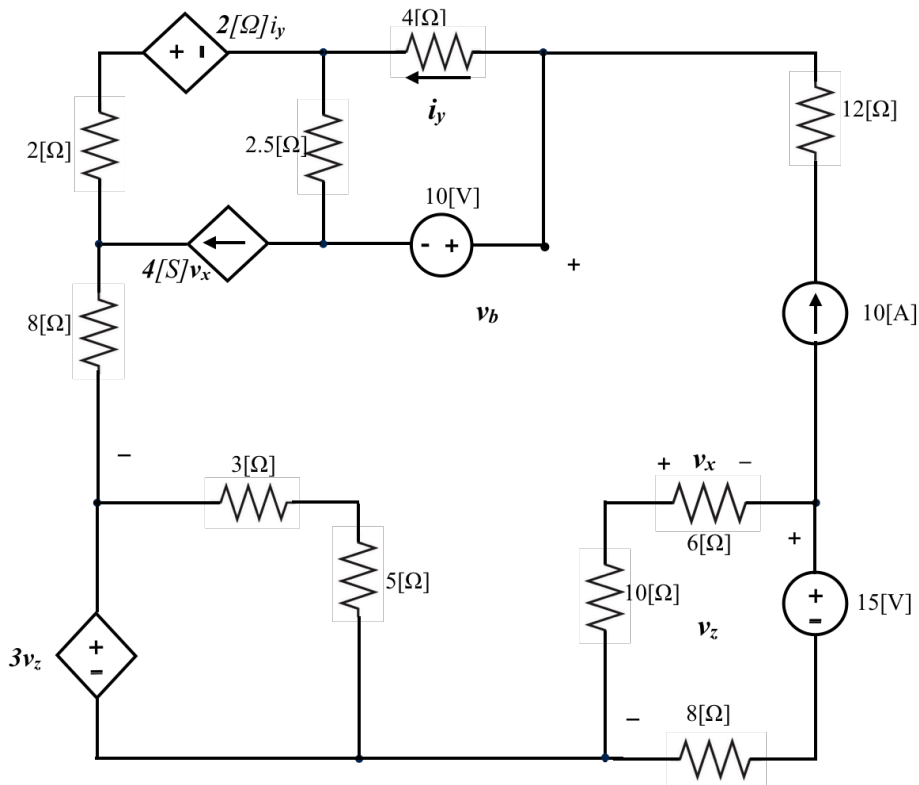

Room for extra work

1. {35 Points} Use the **node-voltage method** to write a complete set of equations that could be used to solve this circuit. Do not simplify the circuit. Do not attempt to simplify or solve your equations. **Define all variables clearly.**

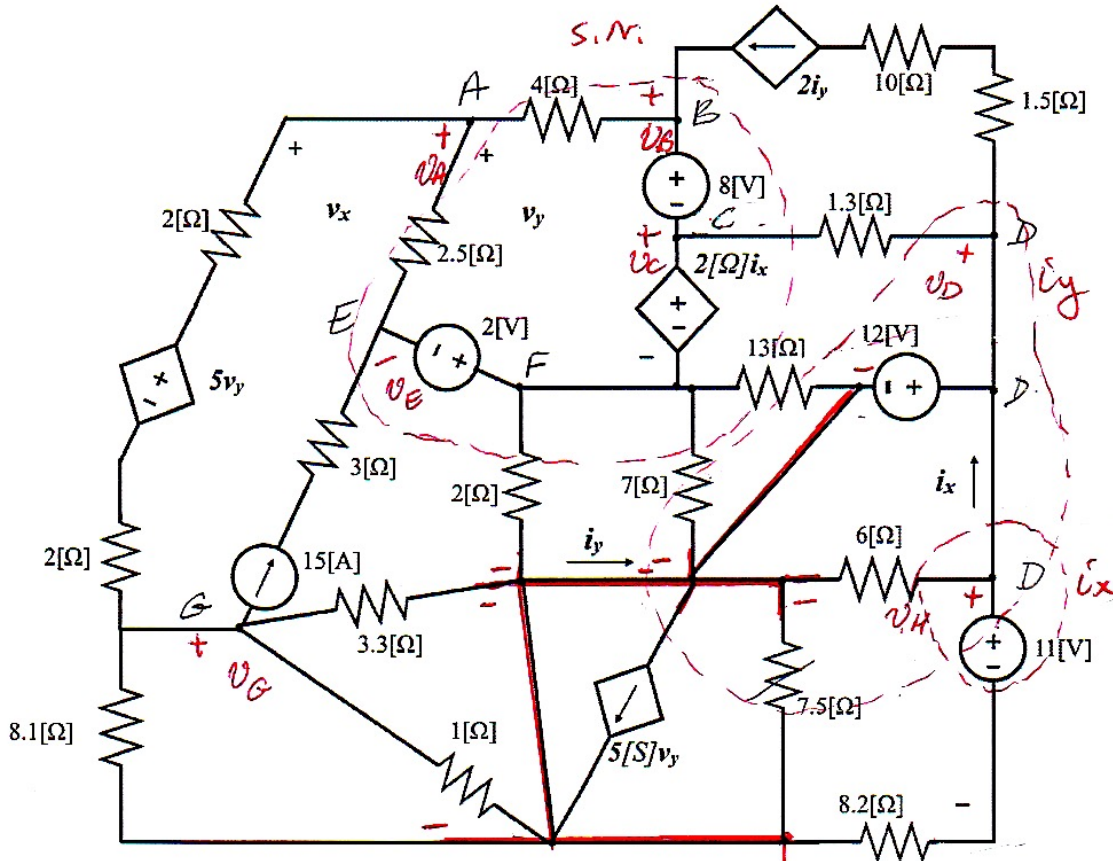

7 node voltage eqs. } 11 eqs.
4 auxiliary eqs.

$$\textcircled{A} \quad \frac{v_A - 5v_y - v_G}{4[\Omega]} + \frac{v_A - v_E}{2.5[\Omega]} + \frac{v_A - v_B}{4[\Omega]} = 0$$

$$\textcircled{\text{S.N.}} \quad -2i_y + \frac{v_B - v_A}{4[\Omega]} + \frac{v_E - v_A}{2.5[\Omega]} - 15[\text{A}] + \frac{v_F}{2[\Omega]} + \frac{v_F}{7[\Omega]} + \frac{v_F}{13[\Omega]} + \frac{v_C - v_D}{1.3[\Omega]} = 0$$

$$\textcircled{\text{B+C}} \quad v_B - v_C = 8[\text{V}]$$

$$\textcircled{\text{C+F}} \quad v_C - v_F = 2i_x$$

$$\textcircled{\text{F+E}} \quad v_F - v_E = 2[\text{V}]$$

$$\textcircled{\text{D}} \quad v_D = 12[\text{V}]$$

Room for extra work

$$\textcircled{G} \quad \frac{v_G + 5v_y - v_A}{4[\Omega]} + 15[A] + \frac{v_G}{8.1[\Omega]} + \frac{v_G}{1[\Omega]} + \frac{v_G}{3.3[\Omega]} = 0$$

$$\textcircled{I_x} \quad i_x + \frac{v_D}{6[\Omega]} + \frac{v_D - 11[V]}{8.2[\Omega]} = 0$$

$$\textcircled{I_y} \quad -i_y + 5[S]v_y + \frac{v_D - 11[V]}{8.2[\Omega]} + 2i_y + \frac{v_D - v_c}{1.3[\Omega]} - \frac{v_F}{13[\Omega]}$$

$$- \frac{v_F}{7[\Omega]} = 0$$

$$\textcircled{V_y} \quad v_y + 2[V] + v_E - v_A = 0$$

$$\textcircled{V_x} \quad v_x = v_A - v_D - 11[V] \quad \text{Not needed (no dependent source w/ } v_x)$$

2. {30 Points} Use the circuit shown below to solve.
- Find and draw the Norton equivalent seen by the independent current source 3[mA].
 - Find the power delivered by the independent current source 3[mA].
 - Which way (direction) electrons are moving when crossing the terminal A?

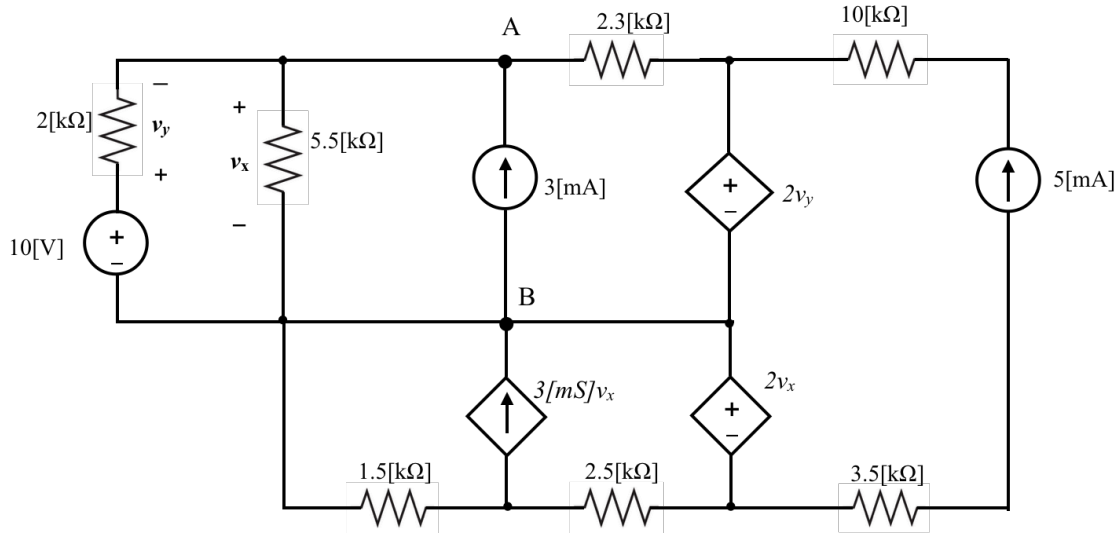

Disconnect 3[mA] source and short A & B. to find i_{sc} .

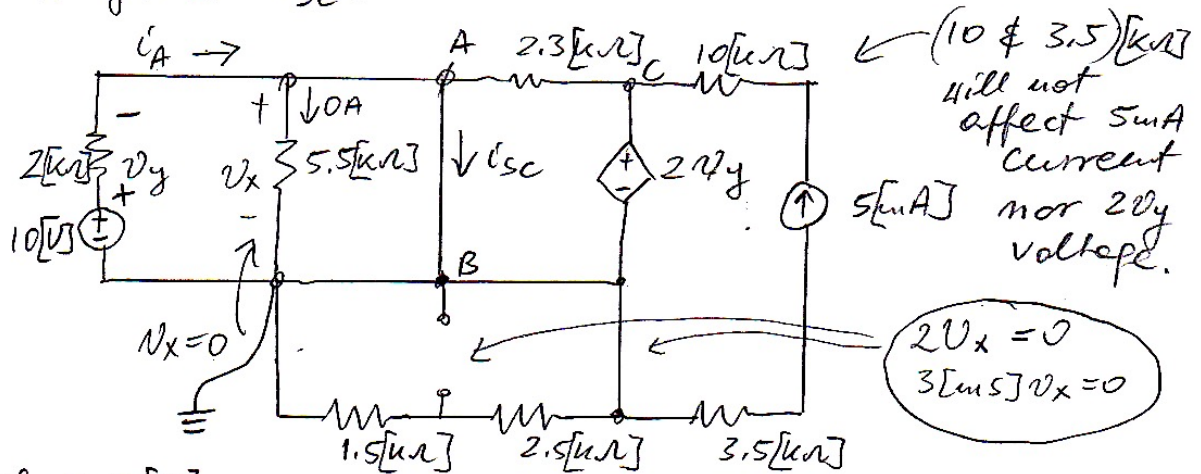

$v_y = 10[V]$

$v_c = 2v_y = 20[V]$; $i_A = \frac{10[V]}{2[k\Omega]} = 5[mA]$

$\text{KCL @ A} \quad -i_A + i_{sc} - \frac{20[V]}{2.3[k\Omega]} = 0 \rightarrow i_{sc} = 13.7[mA]$

Room for extra work

Find R_{TH}

Deactivate independent sources & connect a test source.

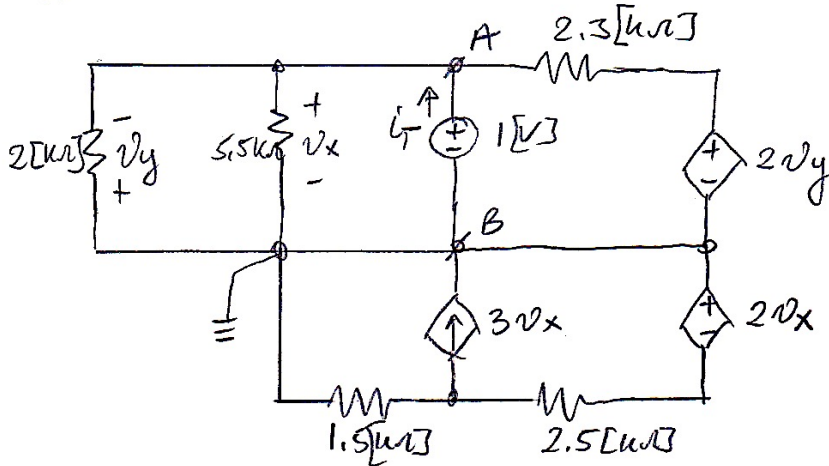

$$\begin{aligned} v_x &= 1[V] \\ v_y &= -1[V] \\ v_A &= 1[V] \end{aligned}$$

$$\text{KCL @ A} \quad -i_T + \frac{v_A}{5.5[k\Omega]} + \frac{v_A}{2[k\Omega]} + \frac{v_A - 2v_y}{2.3[k\Omega]} = 0$$

$$i_T = 1.986[\mu A]$$

$$R_{TH} = 0.5035[k\Omega] = 503.5[\Omega]$$

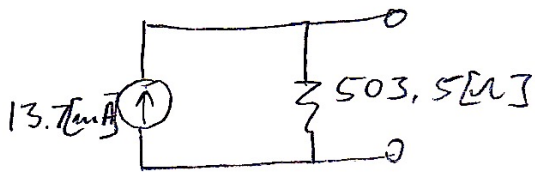

Norton equivalent

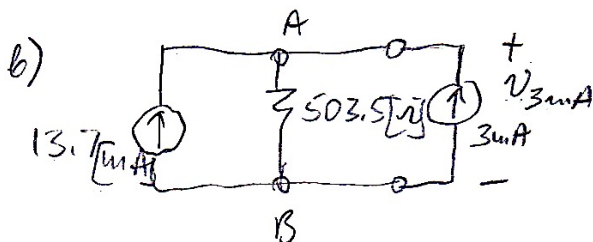

$$\begin{aligned} v_{3mA} &= 503.5 \cdot (3 + 13.7) = \\ &= -8408[V] \end{aligned}$$

$$\begin{aligned} P_{del, 3mA} &= v_{3mA} \cdot 3[\mu A] = \\ &= 25123[\mu W] \end{aligned}$$

c) Electrons move down when passing terminal (A)

So power is delivered

3. {35 Points} A device shown in Figure 1 can be modeled as a voltage source in series with a resistance. The relationship between the voltage across the device and the current through the device is shown in Figure 1. This device is connected to the circuit as shown in Figure 2.

Power delivered by the independent current source 1[mA] is measured as 7.5 [mW].

- Find the model of this device operating in the circuit below (Figure 2), and draw it, showing terminals **A** and **B**.
- Find the coefficient **k** in the dependent voltage source kv_x .
- Are the electrons losing or gaining energy while moving through the dependent voltage source kv_x ? Briefly explain your answer.

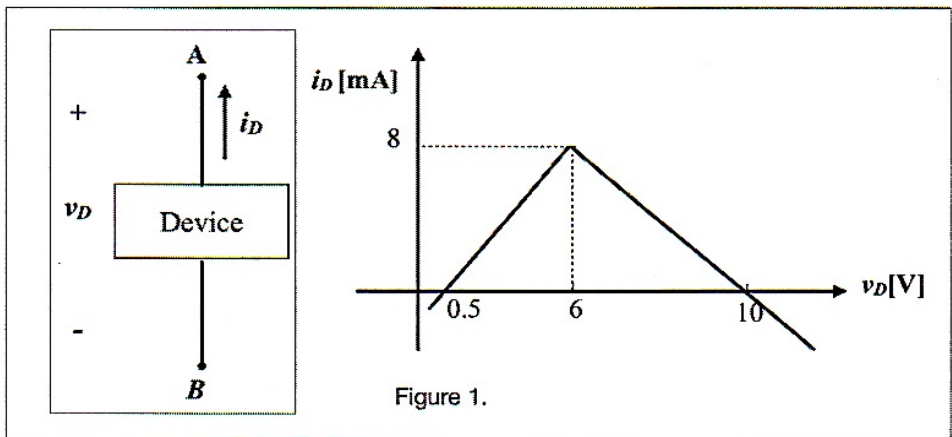

$P_{del, 1mA} = 7.5 [mW]$
 $V_{1mA} = 7.5 [V]$
 Model:

 $i_D = 0 \quad v_D = v_S = 10 [V]$
 $-10 [V] + 8 [mA] \cdot R_S = 6 [V]$
 $R_S = 0.5 [\Omega]$

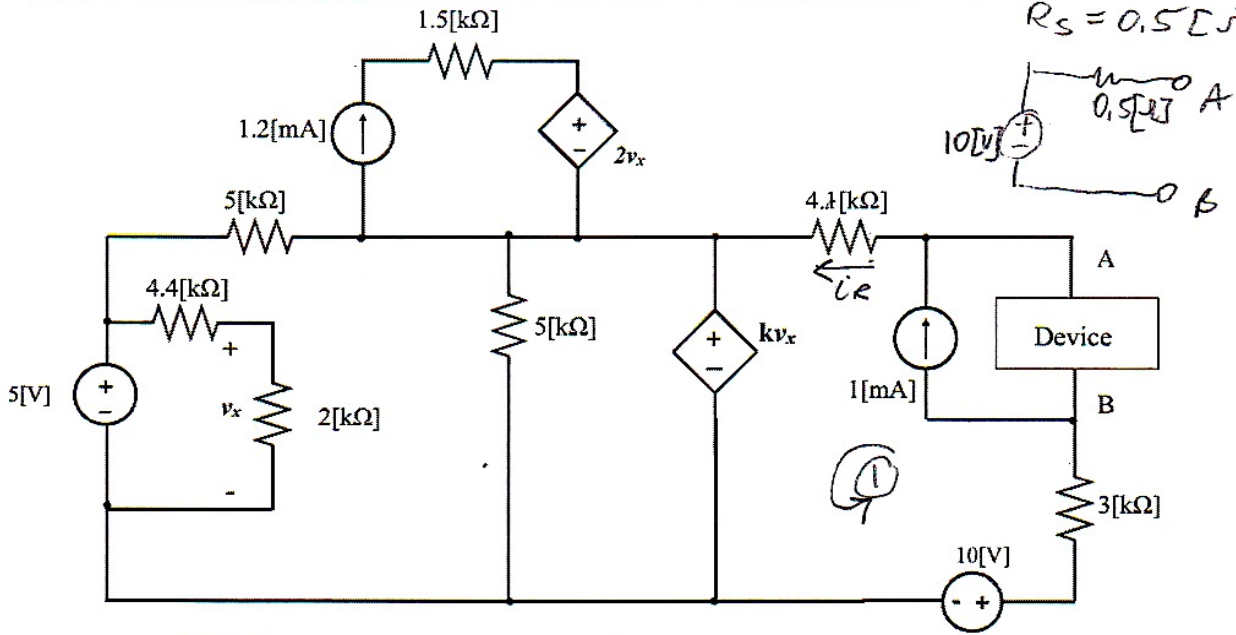

Figure 2.

a)
$$v_x = \frac{5[V] \cdot 2[\Omega]}{(4.4 + 2)[\Omega]} = 1.563 [V]$$

Room for extra work

$$P_{Del, 1mA} = 7.5 [\mu V] \quad v_{1mA} \uparrow 1 [\mu A]$$

$$v_{1 [\mu A]} = 7.5 [V]$$

Device: $v_{A-B} = 7.5 [V] \rightarrow v_D = 7.5 [V]$

From $i_D(v_D) = -\frac{8}{4} v_D + 20$

$$i_D(7.5 [V]) = 5 [\mu A]$$

b) KCL @ A $i_R = 1 [\mu A] + 5 [\mu A] = 6 [\mu A]$

KVL in $\textcircled{1}$ $-10 [V] + 6 [\mu A] \cdot 3 [\mu \Omega] - 7.5 [V] +$
 $+ 6 [\mu A] \cdot 4.1 [\mu \Omega] + k \cdot 1.563 [V] = 0$

$$k = -16.06$$

$$k v_x = -25.1 [V]$$

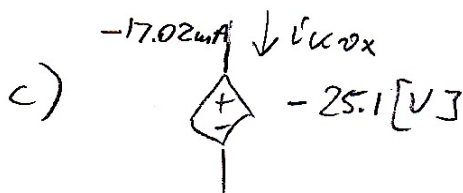

so the source absorbs the power, therefore electrons are losing energy while moving through this source

$$i_{k v_x}$$

\textcircled{KCL} $\frac{k v_x - 5v}{5 [\mu \Omega]} + \frac{k v_x}{5 \mu \Omega} + i_{k v_x} = 0 \rightarrow i_{k v_x} = -17.02 [\mu A]$

Room for extra work

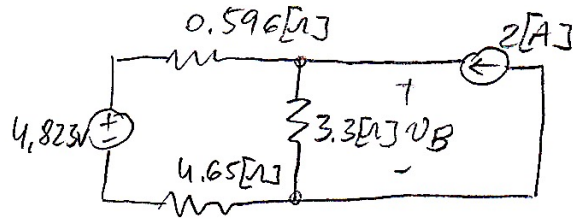
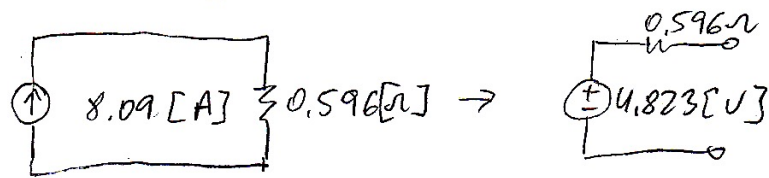
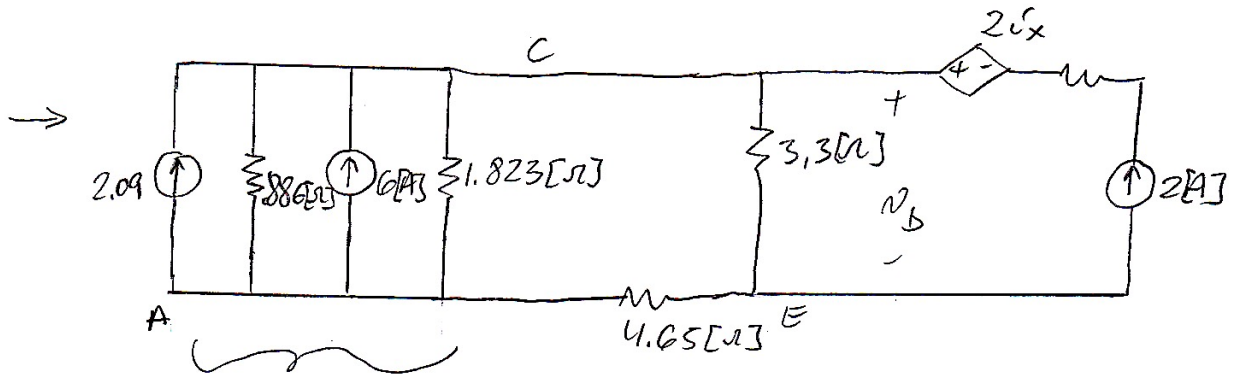

$$\frac{V_B}{3.3[\Omega]} + \frac{V_B - 4.823[V]}{(0.596 + 4.65)[\Omega]} - 2[A] = 0$$

$$V_B = 5.914[V]$$

5. {35 Points} In the following circuit, we will connect a load resistor R_L that will ensure maximum power delivered to this load R_L .

a) Find the value of R_L for this maximized power delivery.

b) Find the Thevenin equivalent seen by R_L and draw it showing terminals A and B.

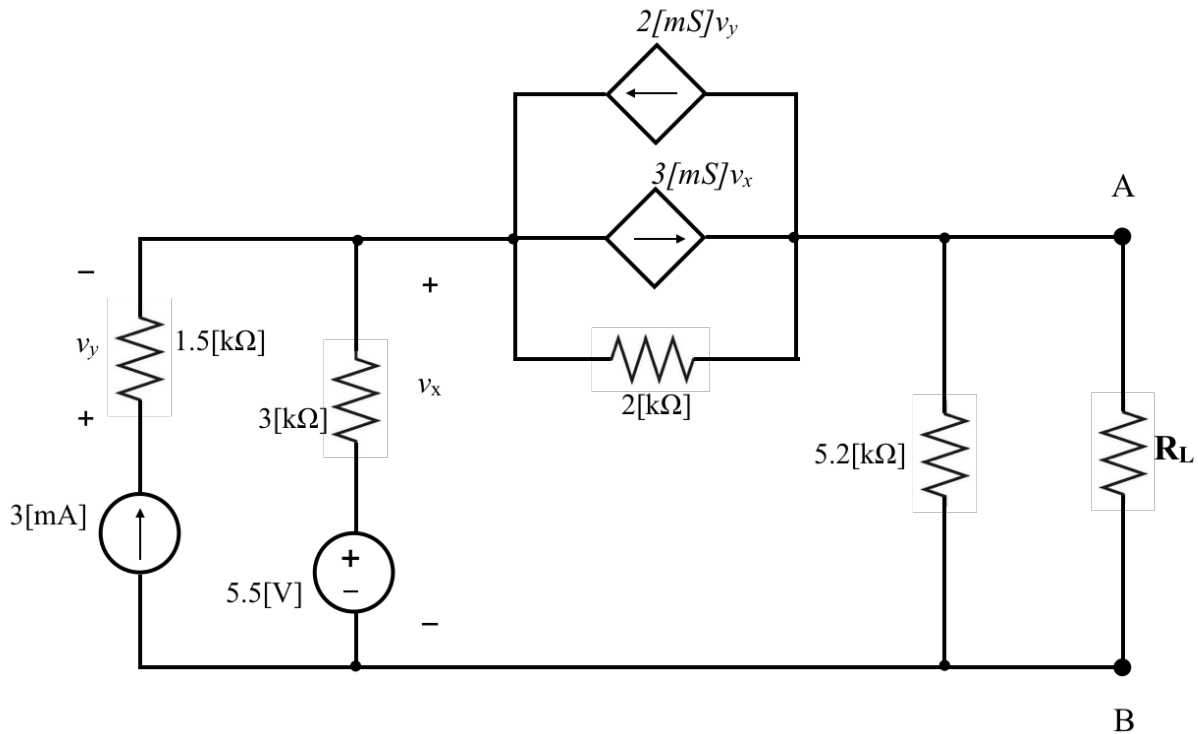

- a)
- Disconnect R_L and find R_{TH}^B seen @ A & B terminals.
 - Deactivate independent sources & connect a test source @ A & B.

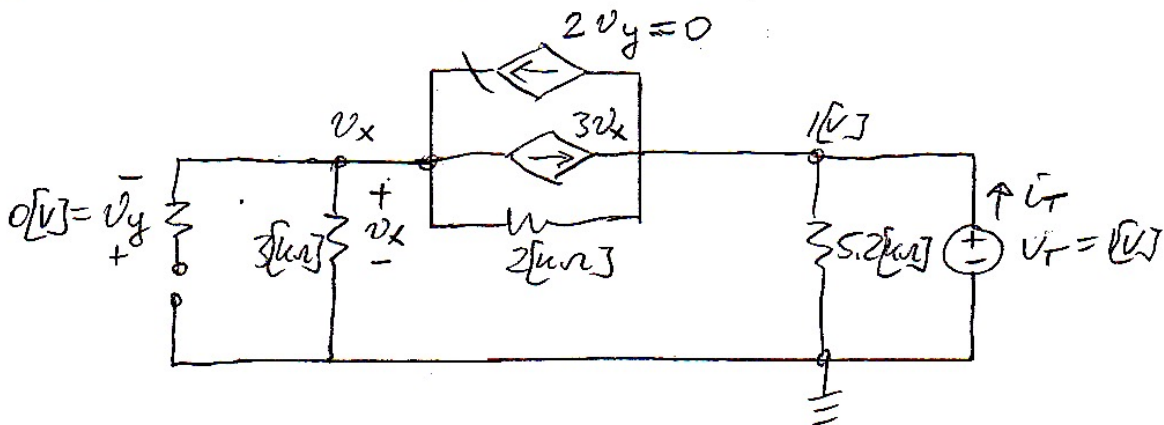

Room for extra work

$$\text{KCL @ } v_x \quad \frac{v_x}{3[\text{k}\Omega]} + 3[\text{mS}]v_x + \frac{v_x - 1[\text{V}]}{2[\text{k}\Omega]} = 0$$

$$\downarrow \\ v_x = 0,13[\text{V}]$$

$$\text{KCL @ } v_T \quad i_T - \frac{1[\text{V}]}{5,2[\text{k}\Omega]} - \frac{v_x}{3[\text{k}\Omega]} = 0$$

$$i_T = 0,236[\text{mA}]$$

$$R_{TH} = \frac{1[\text{V}]}{0,236[\text{mA}]} = 4,241[\text{k}\Omega]$$

b) Remove R_L and short A & B to find i_{sc} .

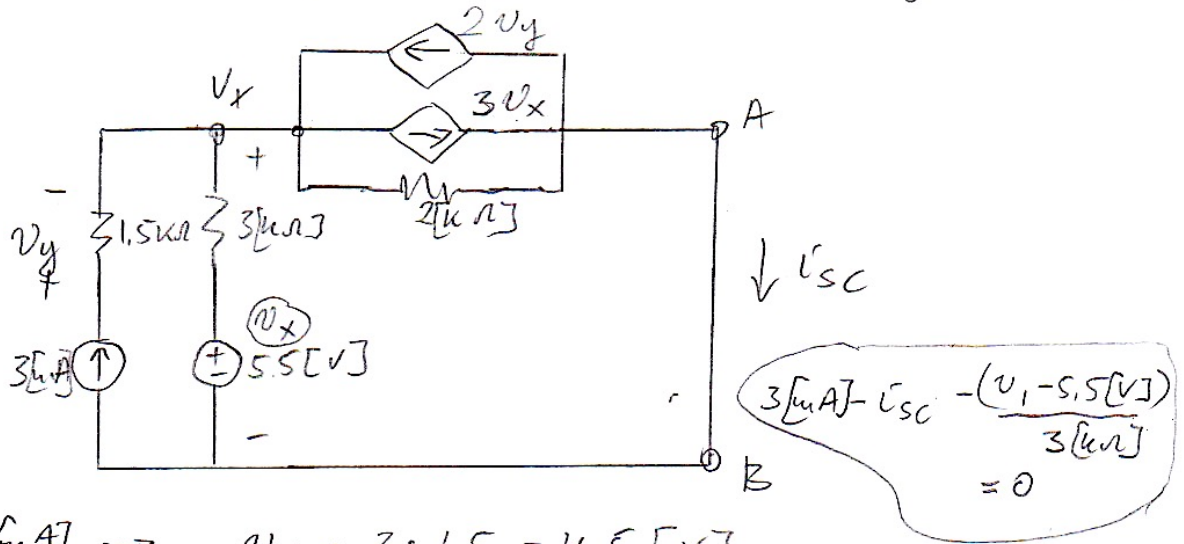

$$3[\text{mA}] \rightarrow v_y = 3 \cdot 1,5 = 4,5[\text{V}]$$

$$-3[\text{mA}] + \frac{v_x - 5,5[\text{V}]}{3[\text{k}\Omega]} - 2[\text{mS}] \cdot 4,5[\text{V}] + 3v_x + \frac{v_x}{2[\text{k}\Omega]} = 0$$

$$v_x = 3,6[\text{V}] \rightarrow i_{sc} = 3,633[\text{mA}]$$

$$V_{TH} = i_{sc} \cdot R_{TH} = 15,41[\text{V}]$$

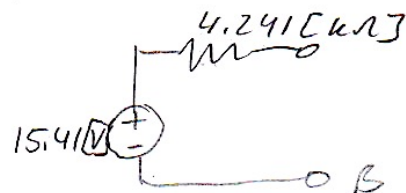

6. {35 Points} Use the circuit shown below to solve this problem.
 b) Use the superposition principle to find the voltage v_b .

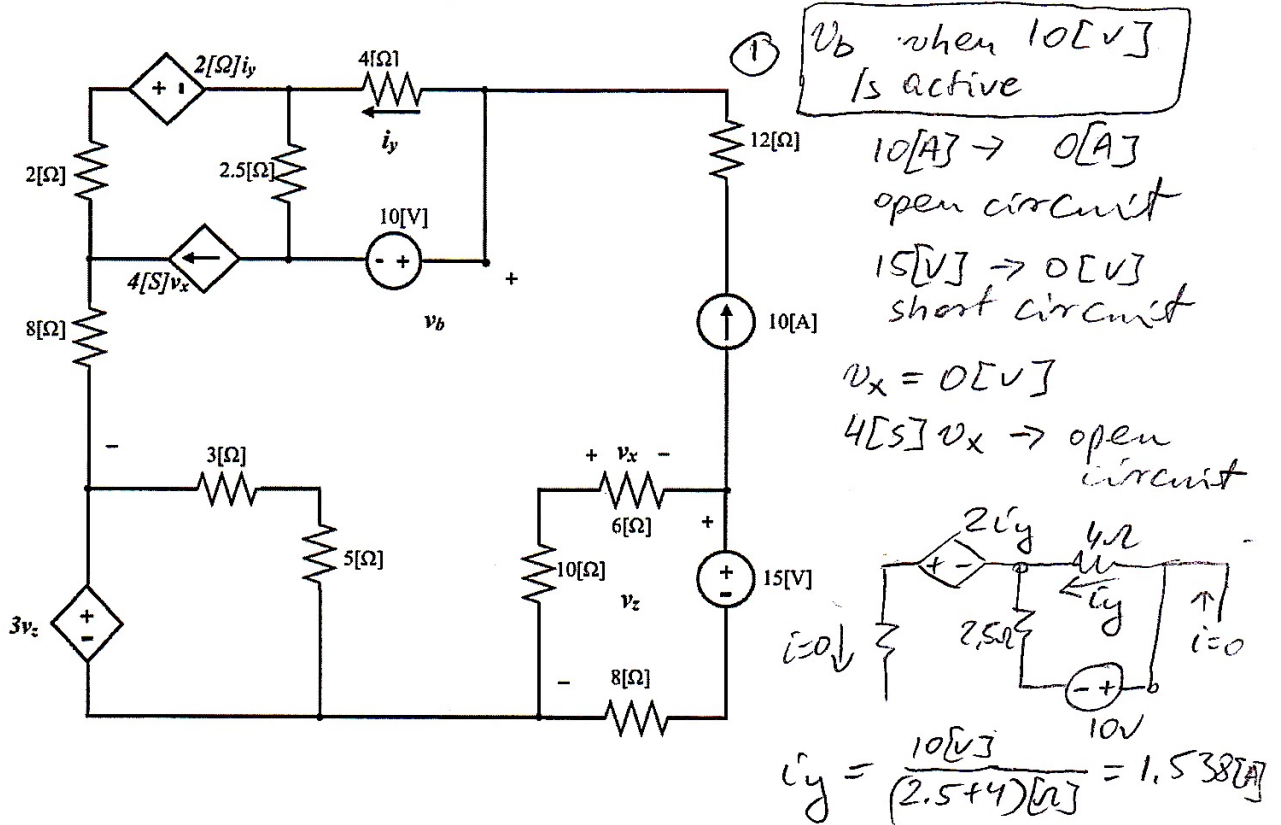

$$v_{b1} = 10[V] - 2.5[\Omega] \cdot 1.538[A] - 2 \cdot 1.538 = 3.079[V]$$

10[V] OFF \rightarrow shorted
 10[A] OFF \rightarrow open circuit

② $15[V]$ ON

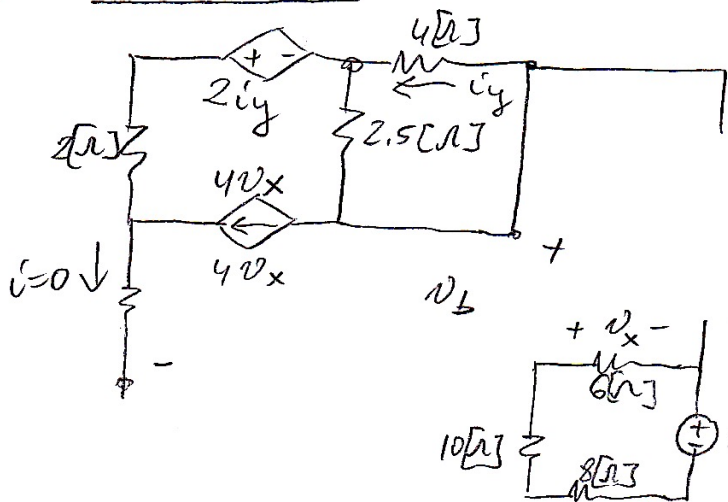

$$v_x = -\frac{15[V] \cdot 6[\Omega]}{(6+10+8)[\Omega]}$$

$$= -3.75[V]$$

$$4v_x = -15[A]$$

$$i_y = -4v_x \cdot \frac{2.5}{6.5} \cdot \frac{1}{4} = +5.769[A]$$

$$v_{b2} = 4[\Omega] \cdot (+5.769[A]) - 2(+5.769) + 2[\Omega] \cdot 4v_x = 41.59[V]$$

Room for extra work

- ③ 10[A] ON
 10[V] OFF (shorted)
 15[V] OFF (shorted)

Rednro

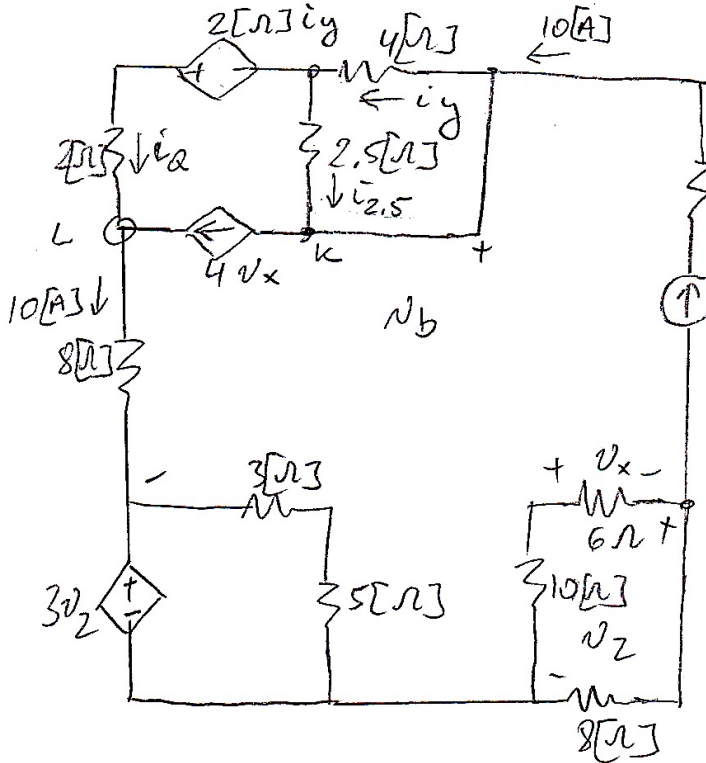

$$v_x = 10[A] \cdot \frac{(10+6) \cdot 8}{10+6+8} \cdot \frac{1}{10+6} \times 6[\Omega] = 2[V]$$

KCL @ K

$$-10[A] + i_y - i_{2.5} + 4v_x = 0$$

$$i_{2.5} \cdot 2.5[\Omega] = -i_y \cdot 4[\Omega]$$

$$i_y = -26.92[A]$$

$$i_{2.5} = -43.08[A]$$

KCL @ L $10[A] - 4v_x - i_Q = 0$

$$i_Q = 10 - 80 = -70[A]$$

Nb3

$$= 43.08 \cdot 2.5 + 2 \cdot 26.92 + 2 \cdot 70 + 10[A] \cdot 8[\Omega] = -193.8 [V]$$

$$V_b = v_{b1} + v_{b2} + v_{b3} = -149.2 [V]$$