

Name: \_\_\_\_\_ (Print)

Signature \_\_\_\_\_

Date: \_\_\_\_\_

**ECE 2300 -- Quiz #4**  
S.R. Brankovic Section – MW 11:30 AM  
October 26, 2005

**KEEP THIS QUIZ CLOSED AND FACE UP  
UNTIL YOU ARE TOLD TO BEGIN.**

1. This quiz is closed book, closed notes.
2. Show all work on these pages. Show all work necessary to complete the problem. A solution without the appropriate work shown will receive no credit. A solution which is not given in a reasonable order will lose credit. **If your work continues on to another page, indicate clearly where your work can be found. Failure to indicate this clearly will result in a loss of credit.**
4. Show all units in solutions, intermediate results, and figures. Units in the quiz will be included between square brackets.
5. Do not use red ink. Do not use red pencil.
6. You will have 25 minutes to work on this quiz.

\_\_\_\_\_/100 %

**Problem #1.**

Find which two terminals of the device shown in Figure 1A should be connected to the circuit terminals A and B shown in Figure 1B in order to achieve the maximum power delivery to the device. Assuming the values for  $R=1\ [\Omega]$ ,  $v_o=2\ [V]$  and  $i_o=1\ [A]$  find what is the value of the maximum power absorbed by device.

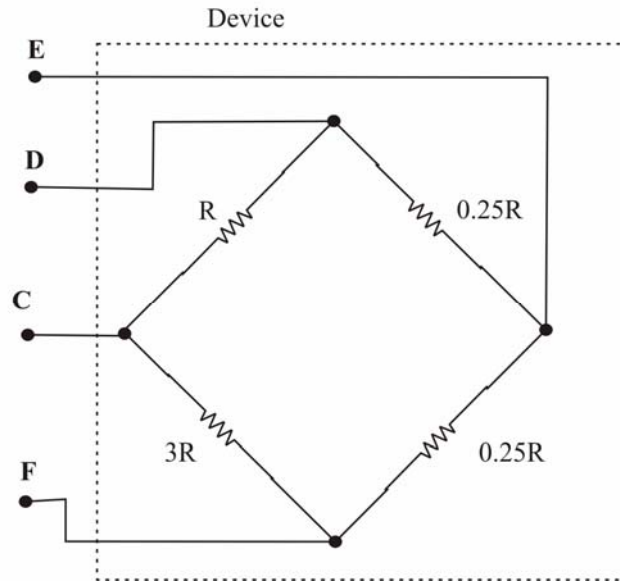

Figure 1A

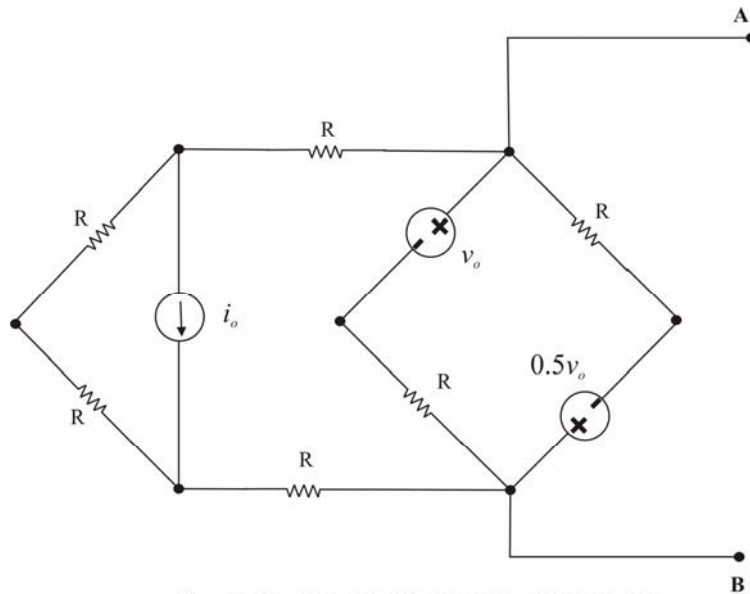
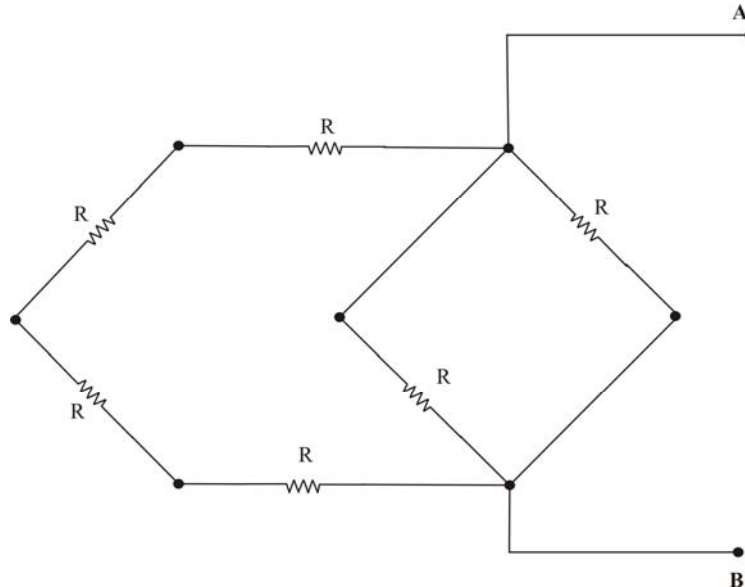

Figure 1B

**Solution:**

The main thing to know in order to solve this problem is to recognize that maximum power transfer to the device will occur if the equivalent resistance of the device is equal to the RTH of the circuit in Figure 1B. In order to find RTH you need to consider the circuit form Figure 1B with the independent sources taken out. The resulting circuit is presented below.



**Figure 2.**

The  $R_{Th}$  as seen from terminals A and B is than:

$$R_{Th} = (R + R + R + R) \parallel R \parallel R$$

$$\Rightarrow R_{Th} = \frac{4}{9} R$$

Now we need the right combination of terminals on our device to be connected to our circuit in order to get maximum power transfer (power delivery) to our device. The right combination is the one with respect to which we will have the  $R_{eq}=R_{Th}$ . So let's have a look to the device shown in Figure 1A. We can see that we do have four resistors connected to their ends, where two of them, have the same value of resistance ( $0.25 [\Omega]$ ). Also if we look closer, we will see that connection to the terminals **E** and **D**, and terminals **E** and **F** are equivalent with respect to the resulting  $R_{eq}$  of the device. It is obvious that these combinations are not the right choice,  $R_{eq}=4.25/10 [\Omega]$ . Now we have to look which one of four other remaining combinations is good. If we look diagonal combinations, **D** and **F** vs. **C** and **E**, we can write that

$$R_{DF} = \frac{0.5R \cdot 4R}{0.5R + 4R}; \quad \text{and} \quad R_{CE} = \frac{1.25R \cdot 3.25R}{1.25R + 3.25R}$$

Obviously, both sides have the same denominator; however we can see, if we multiply the numerator and denominator with 2 in each fraction, the  $R_{DF}$  is the right equivalent

resistance for the device ( $4/9 \text{ } [\Omega]$ ) and **that the combination of terminals D and F gives us the maximum power transfer.**

Now we have to estimate what is the maximum power absorbed by our device if it is connected to terminals A and B. Recovering the equation from the class, the maximum power absorbed by device is given by (Figure 3):

$$P_{MAX,ABS} = \frac{v_{Th}^2}{4R_{device}} = \frac{v_{Th}^2}{4R_{Th}} ;$$

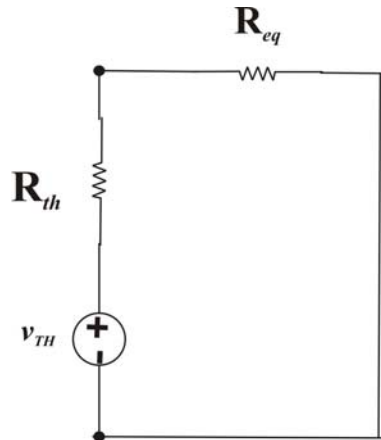

**Figure 3.**

We have to find the  $v_{Th}$  of the circuit on Figure 1B. This could be done on many ways, and I will choose the one that starts with source transformation. So let's do current source transformation, the resulting circuit is shown in Figure 4

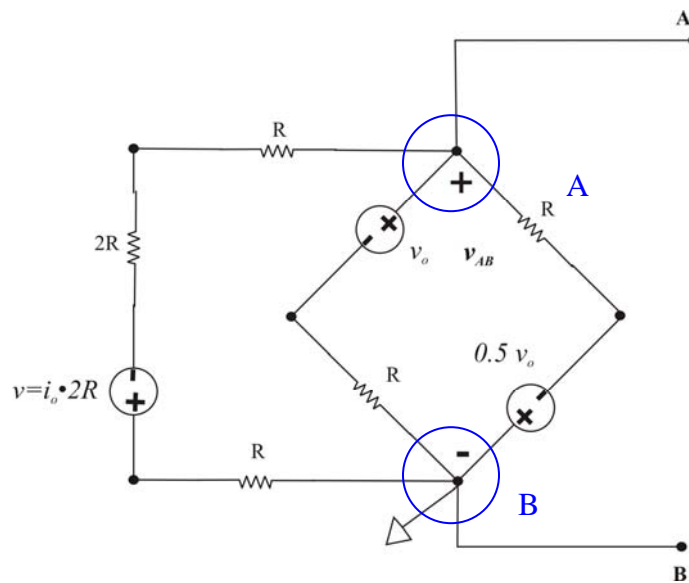

**Figure 4.**

Now we can use the node voltage method to find the open circuit potential on terminals A and B. This potential is equal to  $v_{AB}$  or the node voltage of essential node A with respect to the reference node B, marked on the Figure 4.

So, the KCL for the node A is:

$$\frac{v_{AB} + 0.5 \cdot v_o}{R} + \frac{v_{AB} - v_o}{R} + \frac{v_{AB} + i_o \cdot 2R}{4R} = 0$$

or

$$v_{Th} = v_{AB} = \frac{2v_o - i_o \cdot 2R}{9} = \frac{2}{9}[V],$$

Now the maximum power absorbed by device is:

$$P_{MAX,ABS} = \frac{v_{Th}^2}{4R_{Th}} = \frac{1}{36}[W].$$

