

Name: SOLUTION (please print)

Signature: _____

ECE 2201 – Quiz #4
April 8, 2019

Keep this quiz closed and
face up until you are told to
begin.

1. This quiz is closed book, closed notes. You may use one 8.5" x 11" crib sheet, or its equivalent.
2. Show all work on these pages. Show all work necessary to complete the problem. A solution without the appropriate work shown will receive no credit. A solution which is not given in a reasonable order will lose credit.
3. It is assumed that your work will begin on the same page as the problem statement. If you choose to begin your work on another page, you must indicate this on the page with the problem statement, with a clear indication of where the work can be found. **If your work continues on to another page, indicate clearly where your work can be found. Failure to indicate this clearly will result in a loss of credit.**
4. Show all units in solutions, intermediate results, and figures. Units in the quiz will be included between square brackets.
5. Do not use red ink. Do not use red pencil.
6. You will have 30 minutes to work on this quiz.

_____/20

Room for extra work

4pm class

Use either the **node-voltage method** or the **mesh-current method** to write a complete set of equations that could be used to solve this circuit. Do not simplify the circuit. Do not attempt to solve or simplify your equations. Define all variables.

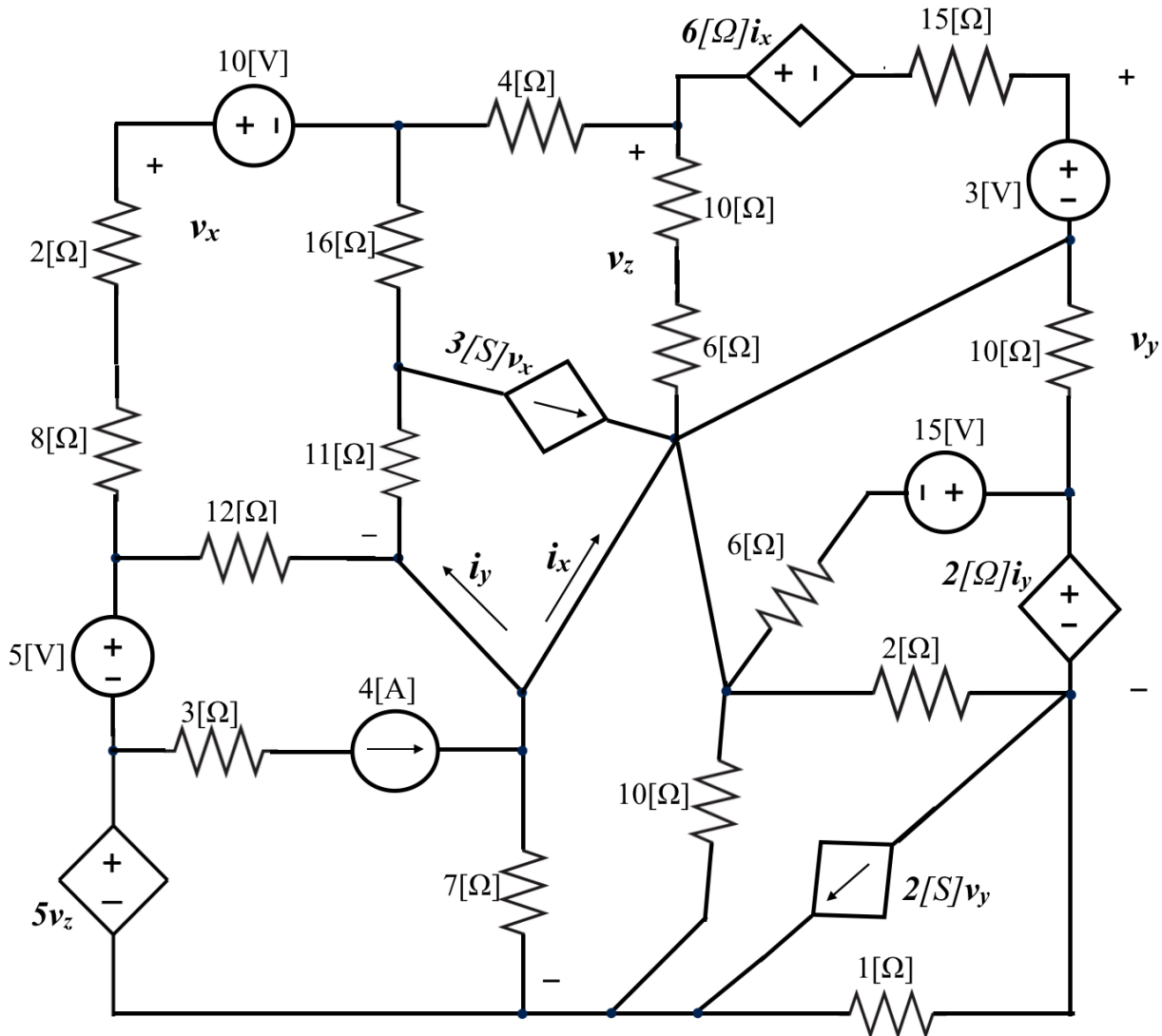

Use either the **node-voltage method** or the **mesh-current method** to write a complete set of equations that could be used to solve this circuit. Do not simplify the circuit. Do not attempt to solve or simplify your equations. Define all variables.

8 node eqs, 5 auxiliary eqs, } 13 eqs.

(A)
$$\frac{v_A - v_D}{16[\Omega]} + \frac{v_A + 10 - v_C}{(2+8)[\Omega]} + \frac{v_A - v_B}{4[\Omega]} = 0;$$

(B)
$$\frac{v_B - v_A}{4[\Omega]} + \frac{v_B}{(10+6)[\Omega]} + \frac{v_B - 6[\Omega]i_x - 3[V]}{15[\Omega]} = 0$$

(C+F)
$$\frac{v_C - 10[V]}{(2+8)[\Omega]} + \frac{v_C}{12[\Omega]} + 4[A] + \frac{v_G}{7[\Omega]} + \frac{v_G}{10[\Omega]} - 2v_y + \frac{v_G - v_H}{1\Omega} = 0$$

Room for extra work

$$V_C - V_F = 5[V] \quad ; \quad \textcircled{D} \quad \frac{V_D - V_A}{16[\Omega]} + 3V_x + \frac{V_D}{11[\Omega]} = 0$$

$$V_F - V_G = 5V_z$$

$$\frac{V_H - V_G}{12[\Omega]} + 2V_y + \frac{V_H}{2[\Omega]} + \frac{V_E - 15[V]}{6[\Omega]} + \frac{V_E}{10[\Omega]} = 0$$

$$V_E - V_H = 2V_y$$

$$-V_x - 3V_x + \frac{V_B - V_A}{4[\Omega]} + \frac{V_H - V_G}{12[\Omega]} - \frac{V_G}{10[\Omega]} = 0$$

$$-V_y - \frac{V_D}{11[\Omega]} - \frac{V_C}{12[\Omega]} = 0$$

$$V_x - V_A + 10[V] = 0$$

$$V_z = V_B - V_G$$

$$V_y = V_H + 3[V]$$

Use either the **node-voltage method** or the **mesh-current method** to write a complete set of equations that could be used to solve this circuit. Do not simplify the circuit. Do not attempt to solve or simplify your equations. Define all variables.

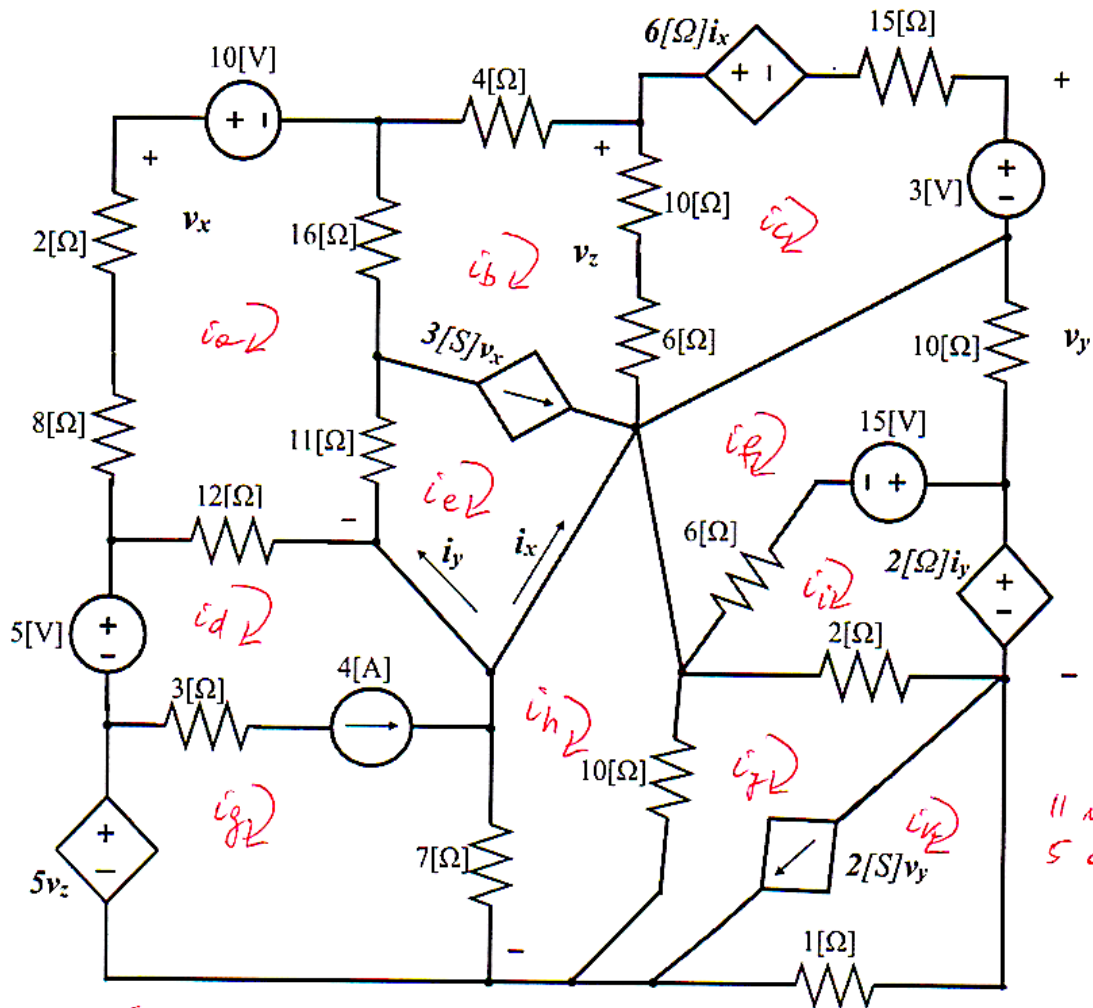

11 mesh eqs,
5 auxiliary eqs.

$$\begin{aligned}
 (i_a - i_b) \cdot 16[\Omega] + (i_a - i_e) 11[\Omega] + (i_a - i_d) 12[\Omega] + i_a(8+2)[\Omega] + 10[V] &= 0 \\
 i_b \cdot 4[\Omega] + (i_b - i_c)(10+6)[\Omega] + (i_e - i_a) 11[\Omega] &= 0 \\
 i_e - i_b &= 3 v_x \\
 (i_c - i_b)(10+6)[\Omega] + 6 v_x + i_c \cdot 15[\Omega] + 3[V] &= 0 \\
 (i_d - i_a) \cdot 12[\Omega] + (i_g - i_h) \cdot 7[\Omega] - 5 v_z - 5[V] &= 0 \\
 i_g - i_d &= 4[A]
 \end{aligned}$$

$$(1h) \quad (v_h - v_g) \cdot 7[\Omega] + (v_h - v_f) \cdot 10[\Omega] = 0$$

$$(1f) \quad v_f \cdot 10[\Omega] + 15[V] + (v_f - v_i) \cdot 6[\Omega] = 0$$

$$(1i) \quad (v_i - v_j) \cdot 2[\Omega] + (v_i - v_f) \cdot 6[\Omega] - 15[V] + 2v_y = 0$$

$$(1j+k) \quad (v_j - v_i) \cdot 2[\Omega] + v_k \cdot 1[\Omega] + (v_j - v_h) \cdot 10[\Omega] = 0$$

$$(1j+k) \quad (v_j - v_k) = 2v_y$$

$$(1x) \quad v_x = v_h - v_e$$

$$(1y) \quad v_y = v_e - v_d$$

$$(1x) \quad v_x - (v_c - v_b) \cdot 12[\Omega] + v_a \cdot (2 + 8)[\Omega] = 0$$

$$(1y) \quad v_y = 3[V] + v_f \cdot 10[\Omega] + 2v_y = 0$$

$$(1z) \quad v_z = (v_b - v_c) \cdot (10 + 6)[\Omega] + (v_g - v_h) \cdot 7[\Omega] = 0$$